

# AMP

Commercial Condensing Water Heater  
**THERMAL** SOLUTIONS

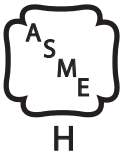

**1000-4000 MBH**



**98%  
EFFICIENT**

Thermal Solutions LLC | PO Box 3244, Lancaster, PA 17604-3244 | 717-239-7642

# EFFICIENCY MEETS SERVICEABILITY

The AMP Condensing Water Heater Series (AMPW) from Thermal Solutions delivers efficiency with unprecedented space saving innovation in a service friendly design. Available in 1000, 1250, 1500, 2000, 2500, 3000, 3500 and 4000 MBH input levels, all models are 98% Thermal Efficient. The 316L stainless steel heat exchanger features cavernous internal circuits with commercially sized tubes that minimize pressure drop and proactively reduce pump in sizing, saving on install and electrical operations.

## WATER HEATER ADVANCEMENT

Commercial grade tubes, nearly twice the size of competitive models, promote self-cleaning and flushing of particulates. Expanded tube and header dimensions promote smaller pumps and more efficient operations.

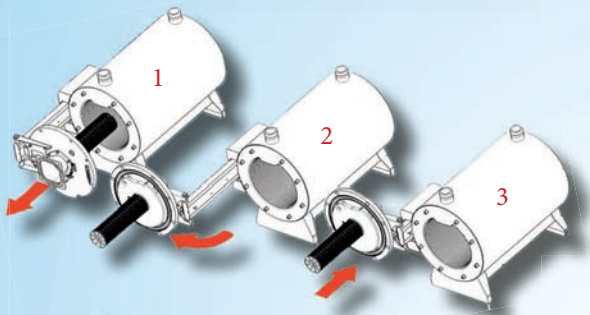

## SPACE SAVING INNOVATION

We moved the burner from the traditional top to the side and reduced required install space by 46%, dramatically limiting the height of the heater. Models 1000-2000mbh fit through standard doorways and are compact for easy maneuvering. All models can be Field Knock Down, with dimensions and instructions for disassembling and assembly on site. Top water and gas connections reduce requirements commonly added to rear dimensions. Designed to fit...an optional racking system doubles the BTUs vs competitive install requirements.

## DUAL FUEL

AMP Water Heaters are dual fuel (natural gas and LP gas) rated. Providing assurances if primary fuel is unavailable or planned change in the future.

Separate gas trains included and center-locking switch for manual transfer provide simple and safe change of fuels.

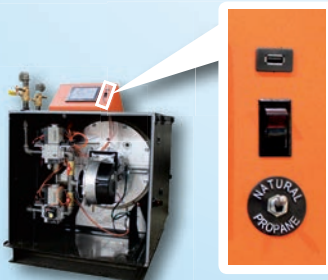

## SERVICEABLE

Doesn't seem like much, but moving that burner "opened up" the industry. The AMP commercial water heater platform from 1000-4000mbh is focused on service, reliability, and longevity. All AMPW models come with supported swing-out door providing complete access to burner and combustion chamber. Service, inspections, and cleanings can be completed with ease, ensuring new, out of the box efficiency and performance for the life of the product.

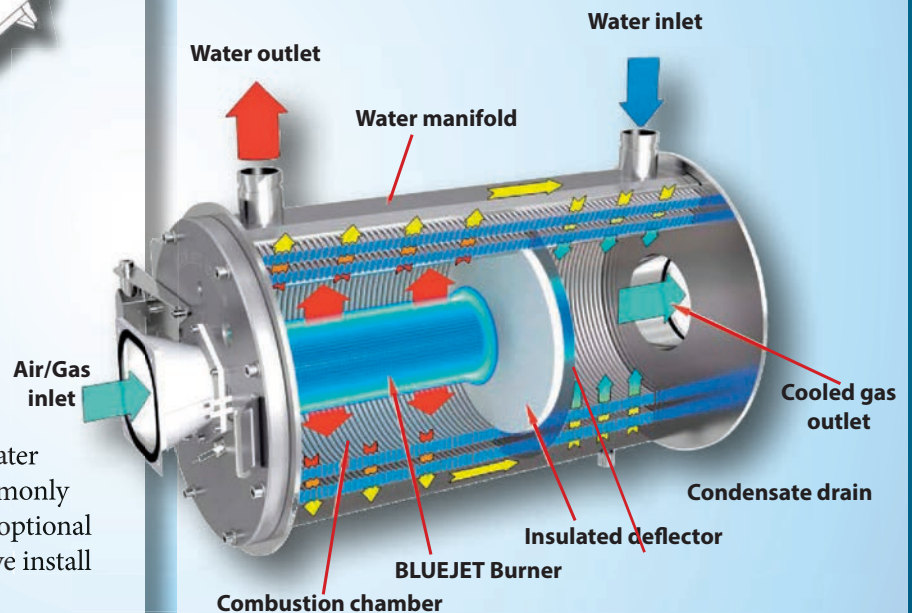

## 5:1 TURNDOWN

Why 5:1 turndown? Because it works and is proven time after time. No need for multiple set-ups in summer and winter or excess amounts of air, robbing your heater's condensing performance.

## VENTING

Cat II or IV venting for either individual or common (engineered) venting systems. Capable of up to 300 equivalent feet of vent in stainless steel, polypropylene or CPVC.

# ADVANCED CONTROL PLATFORM – CONCERT™ CONTROL



## Intuitive Icon Navigation

“Touch” and move through our control menus effortlessly. Whether it be commissioning with the “Quick Setup” menu, pinpointing fault codes with corrective actions in seconds or seamlessly connecting to an EMS. Extensive data archives with graphical displays are available to evaluate performance and make value-added adjustments to maximize heater efficiency.

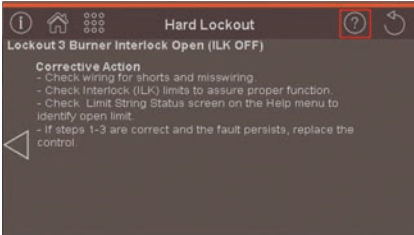

## Self-Guiding Diagnostics

Troubleshooting issues has never been this easy! The industry-leading fault identification and correction feature allows the service technician to quickly drill down on the issue, with cause and corrective measures.



## Unmatched Archives

With the largest collection of stored operational data (4 months), no stone is left unturned when it comes to evaluating a heater’s performance and pinpointing adjustment for improvement. The heater’s onboard energy management system is a true step above all others!

## Peer-To-Peer Sequencing

Unique control logic uses both temperature and firing rate of the connected s to sequence up to eight units in unison to optimize system efficiency. Included dual RJ45 connections make peer-to-peer and/or simultaneous EMS communications (ModBus Standard / Other Protocols Optional) a snap without the need of a separate splitter.



## USB Data Sharing

Make room on the tool belt for a flash drive as the USB data sharing port has become another important device to have in commissioning (upload/download settings from one to the next), servicing (download data and email file to factory for assistance) and analyzing operation (historical info can be downloaded & saved in .CRV formatted files).

# SIMPLIFIED WIRING AND SERVICEABILITY

Low and high voltage fused printed circuit boards (PCB) simplifies wiring, enhances serviceability & troubleshooting with easy to read labeling, and provides electrical protection (spare fuses located on PCB for quick replacement). Other connections include: 120/1/60 voltage and pumps (, system & domestic hot water); alarm; auto & manual reset external limits; enable/disable; DHW demand; 4-20mA remote; sensors (outdoor, remote and DHW); EnviraCOM thermostat; low water cutoff; and flow switch.

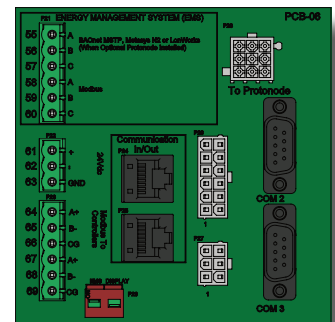

## TANKS & PACKAGING



AMP Water Heaters are commonly paired with storage tanks. Tanks are available to suit all applications: vertical or horizontal orientation; glass, epoxy or cement-lined; metal jacketing and insulation, sprayed foam insulation or bare exterior; and in various shell materials (i.e. stainless steel). Shipped separately for field installation or skid mounted as a factory package.

Visit [www.ThermalSolutions.com](http://www.ThermalSolutions.com) to find out more!

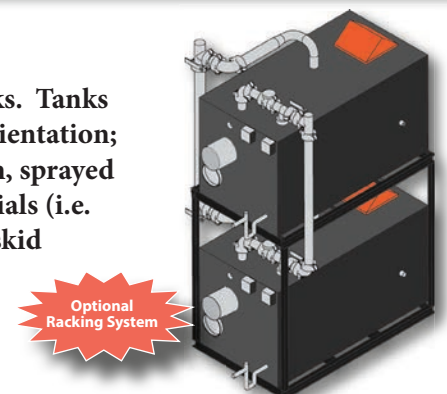

Optional Racking System



## AMP STANDARD EQUIPMENT

### PRESSURE VESSEL DESIGN

Watertube stainless steel heat exchanger  
 ASME Section IV-certified, "HLW" Stamp (1000-2000)  
 ASME Section IV-certified, "H" Stamp (2500+)  
 MAWP 160 PSIG & design temp 210°F  
 Five Year limited heat exchanger warranty  
 Ten year limited pressure vessel warranty  
 One year parts and burner warranty

### COMBUSTION DESIGN

Stainless steel pre-mix burner  
 Low NOx emissions (<10 ppm);  
 Full modulation, 5:1 turndown  
 Natural gas, LP gas, or Dual Fuel  
 4" wc to 14" wc inlet gas pressure  
 8" wc LP min  
 Direct spark ignition system  
 High & low gas pressure switches w/ manual reset  
 Zero governor gas valve  
 Variable speed combustion blower  
 Air proving switch  
 Blocked vent switch

### VENTING

CPVC, polypropylene or stainless steel materials acceptable  
 Air intake - sealed combustion or room air  
 Category II or IV venting  
 Individual or common (engineered) venting systems

### EQUIPMENT

Concert Control™  
 High limit w/ manual reset safety temperature control  
 Low water cutoff w/ manual reset

Water flow switch  
 Supply, return & DHW water temperature sensors  
 Flue gas temperature sensor  
 Condensate trap  
 Blocked condensate switch  
 Pressure & temperature gauge  
 ASME safety temperature & pressure valve  
 Water circulation pump

### ELECTRICAL DESIGN

High voltage printed circuit board (PCB)  
 AMPW1000-2500: 120, 208 or 240 VAC / 60 Hz / 1PH power supply  
 AMPW2500-4000: 208 or 240 VAC / 60 Hz / 1PH power supply  
 AMPW2500-4000: 208, 240 or 460 VAC / 60 Hz / 3PH power supply  
 120 VAC manual reset external limit contacts  
 Three sets of pump contacts  
 PCB fused connections

### Printed Circuit Board (PCB)

24 VAC enable/disable sensor contacts  
 24 to 120 VAC proving switch or auto reset external limit contacts  
 24 to 120 VAC lockout alarm contacts  
 24 VAC EnviraCom thermostat contacts  
 DHW demand contacts  
 Remote header sensor contacts  
 DHW tank sensor contacts  
 Peer-to-peer communication contacts  
 EMS interface contacts  
 Remote 4-20mA contacts

## AMP OPTIONAL EQUIPMENT

- External high limit w/ manual reset safety switch
- Alarm buzzer w/ silencing switch
- Extended Warranty
- Stackable Rack (1000-2000)



## CONCERT CONTROL

### Dashboard - color touch screen display, 4.3"

- Intuitive icon navigation
- "Quick" setup menus
- "Real time" BTU/H display\*

### Temperature demand input

- Time of day setback capability (EnviraCom thermostat must be installed)

### Three (3) pump control

- DHW pump with On/Off or variable speed control
- System pump
- Alternative control to isolation valve, combustion air damper, or standby loss damper
- Pump overrun for heat dissipation
- Pump exercise
- Pump rotor seizing protection

### Peer-to-peer communications

- Multiple size unit sequencing; up to 8 units
- Lead unit automatic rotation

### Energy management system (EMS) interface

- Firing rate and water temperature based algorithms for multiple units; loss of EMS signal defaults to local settings\*
- 4-20mA dc input/output
- ModBus Input/Output
- Simultaneous interface with peer-to-peer

### USB data port transfer\*

- Upload settings between units
- Download parameters for troubleshooting
- Import data into .CRV formatted files for performance analysis

### Energy efficiency enhancer

- Anti-cycling technology
- Multiple unit base load common rate
- Boost temperature & time
- Ramp delay
- Over-temperature safeguarding

### Self-guiding diagnostics

- Identifies fault
- Describes possible problems
- Provides corrective actions

### Time/Date stamp on alarms and lockouts\*

### Unmatched archives

- Historical trends - collects up to 4 months of data
- Event history - up to 3,000 alarms, lockouts, and cycle & run times
- Alarm - limit string faults, holds, lockouts & others
- Cycle & run time - water heaters & pumps
- Resettable

### Domestic hot water priority

- DHW tank piped with priority in the loop
- DHW tank piped as a zone in the system with the pumps controlled by the Concert Control

### Other features

- Factory default settings\*
- Three level password security
- Frost protection
- Contractor contacts (up to 3)
- Low water flow control & indication
- Proportion integral derivative (PID) parameters for DHW, sequencer and fan
- Built-in brown-out protection

\* Unique to Concert Control

## CONCERT CONTROL OPTIONS

- Communications gateway - BACnet, LonWorks, Metasys N2 or ModBus TCP/IP compatible
- 0-10v signal converter
- Header sensor, direct immersion
- Header sensor, well mounted (with well)

## SPECIFICATIONS, DIMENSIONS, & RATINGS

Models	Input		Gross Output (MBH)	DHW Recovery (GPH)*	"A" Length (In)	"B" Width (In)	"C" Height (In)	Gas / LP Conn. (In)	Supply Grooved Conn (In)	Return Grooved Conn (In)	Vent/Air Intake Size (In)	Approx Shipping Weight (Lbs)
	Min (MBH)	Max (MBH)										
AMPW-1000	200	1000	980	1188	45	35	36.5	1 NPT	3	2.5	8	922
AMPW-1250	250	1250	1225	1485	45	35	36.5	1 NPT	3	2.5	8	922
AMPW-1500	300	1500	1470	1782	65	35	36.5	1.25 NPT**	3	2.5	8	1217
AMPW-2000	400	2000	1960	2376	65	35	36.5	1.25 NPT	3	2.5	8	1217
AMPW-2500	500	2500	2450	2970	76	46	49	1.5 NPT	4	4	10	2038
AMPW-3000	600	3000	2940	3564	76	46	49	1.5 NPT	4	4	10	2038
AMPW-3500	700	3500	3430	4158	98	46	49	2 NPT	4	4	12	2485
AMPW-4000	800	4000	3920	4752	98	46	49	2 NPT	4	4	12	2485

\* Based on 40°F to 140°F temperature rise

\*\* AMPW-1500 LP connection (inches) 1 NPT

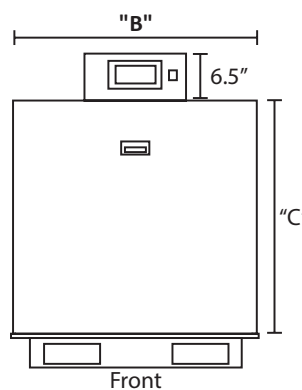
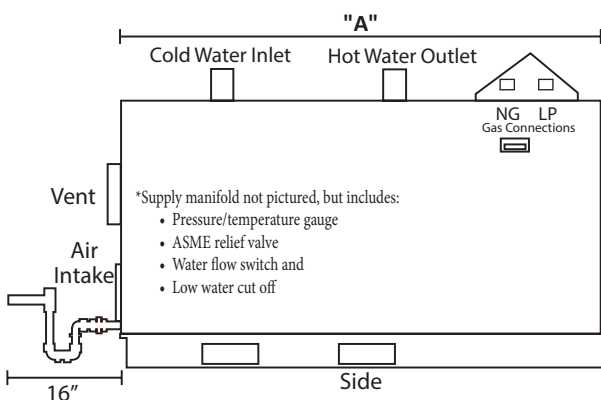

©2019 Thermal Solutions Products, LLC  
 P.O. Box 3244, Lancaster, PA 17604-3244  
 PH: 717-239-7642, F: 877-501-5212

www.ThermalSolutions.com

108599-01 R0